

An Adaptive Sliding Mode Controller Design for DFIG based Wind Turbine System on LabVIEW

Haris CALGAN

Dept. of Electrical-Electronics Engineering
Balikesir University
Balikesir, 10100, Turkey
haris.calgan@balikesir.edu.tr

Metin DEMİRTAS

Dept. of Electrical-Electronics Engineering
Balikesir University
Balikesir, 10100, Turkey
mdtas@balikesir.edu.tr

Abstract— In this paper, adaptive sliding mode control (ASMC) for doubly fed induction generator (DFIG) is proposed. The detailed dynamic model of DFIG is presented in d-q synchronous reference frame. The active and reactive power generated by the DFIG is controlled on the system. Robustness of the controller is improved by using ASMC in order to achieve better performance. Moreover, a simulation model of Wind Energy Conversion System (WECS) is developed by using LabVIEW software. The results of simulation for step change and random turbulent of wind speed are given to show performance of the controller.

Keywords—Doubly fed induction generator, adaptive sliding mode control, LabVIEW, wind power generation

I. INTRODUCTION

Renewable energy sources have become the focus of attention in recent years, because of increasing the consumption of oil resources, the rise in energy prices, environmental issues. Wind Turbine (WT) is one of the most popular among renewable energy sources which has advantages such as the lack of maintenance period, unnecessary permanent staff to work, operating independently from the grid, not to endanger houses, offices or commercial buildings. Additionally, because of its installation, WT does not cause environmental pollution, providing low cost energy transmission [1].

WT has two kinds of working conditions, including fixed speed (1% change in wind speed) and variable speed. While the induction generator used in fixed speed WT connecting directly to the grid, in variable speed WT, it is possible to control the rotor speed with the power electronics unit (20% - 25% of the total amount of capacity) connected to the generator. Thus, the effect of the variable speed wind turbine to the power quality can be improved compared to fixed speed wind turbines [2]. One of the variable-speed machines DFIG has started to prefer in modern wind turbines in recent years that can run at different speeds, it has four-quadrant active-reactive power capability and low converter cost.

Many studies carried out in the literature aim to improve power quality performing active and reactive power control of

DFIG. Vector control approach, taken discrete model of DFIG, is considered the most efficient method that can be used together with conventional PI controller has been involved in research [3]. The same classic controller, when the collapse occurred in the network, how to react in that imbalance and mistakes were analyzed with [4-6].

Vector control approach with a PI controller shows lower performance and worse robustness compared to Sliding Mode Control (SMC). Thus SMC has been more attractive due its advantages such as dealing with unmodeled dynamics, disturbance rejection, fast dynamic responding and insensitivity to parameters variation when the DFIG nonlinearities are considered [7,8].

The design of SMC includes two main steps which are selecting a sliding surface and designing a control signal that forces the system trajectories toward to the sliding surface. During the reaching of system trajectories to the sliding surface, dynamics of the system is still affected by uncertainties. In practice, chattering problem appears in the control effort, which is highly undesirable because of its possibility of creating unmodeled high frequency plant dynamics. Such studies tried to solve this problem by combining different methods [9-11].

In this paper, a sliding mode control strategy applied to a DFIG based wind energy conversion system is proposed. Firstly, wind energy conversion system with different components is modelled. Then, the mathematical model of DFIG is presented and stator flux oriented vector control method combined with an adaptive sliding mode control method which is designed to enhance the tracking precision of the reference active and reactive powers respectively. A simulation study is carried out using LabVIEW simulation environment to evaluate the effectiveness of the proposed control algorithms. The last part is conclusion.

II. WIND ENERGY CONVERSION SYSTEM

The wind conversion system consists of a wind turbine driving a DFIG, a gearbox, and convertors. Through the turbine, the aerodynamic energy is transformed into mechanical energy that rotate main shaft of the generator. The total aerodynamic power extracted by the wind turbine as

in [4] is given by:

$$P_{aer} = \frac{1}{2} \rho \pi R^2 v^3 C_p(\lambda, \beta), \quad (1)$$

where (ρ) is air density (kg/m^3), (R) is blade length (m^2), (v) is wind speed (m/s) and $C_p(\lambda, \beta)$ is the power coefficient that shows the turbine efficiency to convert kinetic energy of the wind into mechanical energy. (λ) is called tip speed ratio between the angular velocity (Ω_r) and the wind speed as

$$\lambda = \frac{\Omega_r R}{v}. \quad (2)$$

Fig.1 is the relationship among C_p , λ and β that presents the maximization of the power for a given wind speed. Maximizing C_p for each wind speed returns the peak power. Therefore, it is desirable for the generator to track maximum C_{p_max} line.

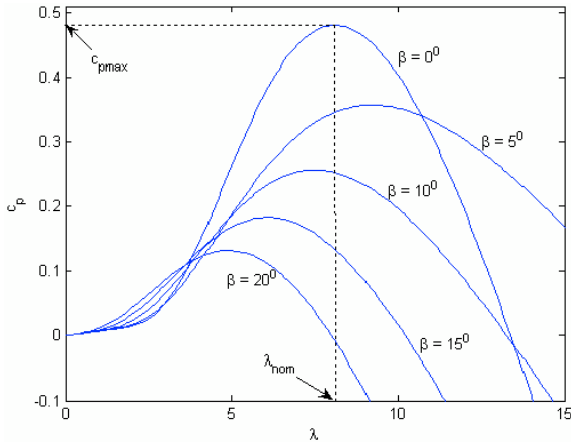

Fig. 1. Power coefficient C_p against λ and β .

III. DFIG MODEL AND INDEPENDENT CONTROL OF ACTIVE AND REACTIVE POWER

A commonly used model for the DFIG is described in the d-q Park reference frame. The following equation system describes stator and rotor voltage and flux equations:

$$V_{sd} = R_s i_{sd} + d\phi_{sd} / dt - \omega_s \phi_{sq} \quad (3)$$

$$V_{sq} = R_s i_{sq} + d\phi_{sq} / dt + \omega_s \phi_{sd}$$

$$V_{rd} = R_r i_{rd} + d\phi_{rd} / dt - \omega_r \phi_{rq} \quad (4)$$

$$V_{rq} = R_r i_{rq} + d\phi_{rq} / dt + \omega_r \phi_{rd}$$

$$\phi_{sd} = L_s i_{sd} + L_m i_{rd} \quad (5)$$

$$\phi_{sq} = L_s i_{sq} + L_m i_{rq}$$

$$\phi_{rd} = L_r i_{rd} + L_m i_{sd} \quad (6)$$

$$\phi_{rq} = L_r i_{rq} + L_m i_{sq}$$

where R_s , R_r , L_s and L_r are the resistances and leakage inductances of the DFIG stator and rotor windings; L_m is the mutual inductance; ω_s and ω_r are the angular frequencies of

stator and rotor currents; $V_{sd}, V_{sq}, V_{rd}, V_{rq}, I_{sd}, I_{sq}, I_{rd}, I_{rq}, \phi_{sd}, \phi_{sq}, \phi_{rd}, \phi_{rq}$ are the d and q components of the space vectors of the stator and rotor voltages, currents, and fluxes.

The mechanical equation is:

$$T_m = T_{em} + F\Omega + J \frac{d\Omega}{dt} \quad (7)$$

The electromagnetic torque depends on the d-q flux and current:

$$T_{em} = N_p \frac{L_m}{L_s} (I_{rd} \phi_{sq} - I_{rq} \phi_{sd}), \quad (8)$$

where F is viscous torque coefficient, Ω is mechanical rotation in angular frequency, J is global inertia, and N_p is number of pairs of poles.

Establishing a link between the values of the stator active-reactive powers and values of the rotor voltages yields independent active and reactive power control of DFIG to be able to easily control the production of electricity from the wind turbine as in [12].

By assuming stable grid, stator flux ϕ_s becomes constant. Moreover, stator resistance R_s can be neglected for generators used in the wind turbine. According to these conditions, a d-q references frame oriented with the stator flux is applied as in [16], the following is obtained:

$$\phi_{ds} = \phi_s \text{ and } \phi_{qs} = 0 \quad (9)$$

The electromagnetic torque is simplified as

$$T_{em} = -N_p \frac{L_m}{L_s} \phi_{sd} i_{rq} \quad (10)$$

By choosing this reference frame, stator voltages (3)-(4) and fluxes (5)-(6) become;

$$V_{ds} = 0, V_{qs} = V_s = \omega_s \phi_{sd},$$

$$\phi_{sd} = \phi_s = L_s i_{sd} + L_m i_{rd}; \phi_{rd} = L_r i_{rd} + L_m i_{sd}, \quad (11)$$

$$\phi_{sq} = 0 = L_s i_{sq} + L_m i_{rq}; \phi_{rq} = L_r i_{rq} + L_m i_{sq}.$$

In d-q reference stator flux oriented frame, the active power (P_s) and reactive power (Q_s) can be written according to the rotor currents as

$$P_s = -V_s \frac{L_m}{L_s} i_{rq}, \quad (12)$$

$$Q_s = \frac{V_s^2}{\omega_s L_s} - V_s \frac{L_m}{L_s} i_{rd}. \quad (13)$$

Reference [14] shows that the arrangement of the equations returns expressions of the rotor currents as

$$i_{rd} = -\frac{R_r}{L_r(1 - \frac{L_m^2}{L_s L_r})} i_{rd} + g \omega_s i_{rq} + \frac{1}{(1 - \frac{L_m^2}{L_s L_r}) L_r} V_{rd} \quad (14)$$

$$i_{rq} = \frac{1}{(1 - \frac{L_m^2}{L_s L_r})} \left(\frac{R_r}{L_r} + \frac{L_m^2 R_s}{L_s^2 L_r} \right) - g \omega_s i_{rd} + \frac{1}{(1 - \frac{L_m^2}{L_s L_r}) L_r} V_{rq} \quad (15)$$

IV. SLIDING MODE CONTROL

The main idea of SMC is to design a control signal that will keep the system in a region that was properly selected according to the states of the system [7].

A. Theory

The design of control system for following nonlinear system is demonstrated [12];

$$\dot{x} = f(x, t) + B(x, t)u(x, t) \quad (16)$$

where $x \in R^n$ is the state vector, $f(x, t) \in R^n$, $B(x, t) \in R^{n \times m}$, $u \in R^m$ are the control vectors.

The general equation to determine the sliding surface given by Slotine and Li is taken as:

$$s(x) = \left(\frac{d}{dt} + \alpha \right)^{n-1} e \quad (17)$$

where $e = (x^d - x)$, $x^d = [x^d, \dot{x}^d, \dots]$, and e is the error on the signal to be adjusted, (α) is a positive coefficient, (n) is the system order, (x^d) is the desired signal, and (x) is the state variable of the control signal.

To bring the state variables to the sliding surface, the following conditions have to be ensured:

$$s(x) = 0, \dot{s}(x) = 0. \quad (18)$$

The control signal (u) derived using (18), is defined by the relation:

$$\begin{aligned} u &= u^{eq} + u^n \\ u^n &= -\kappa \text{sign}(s) \end{aligned} \quad (19)$$

where (u^{eq}) is the equivalent control which forces the state variable to sliding surface, (u^n) is the switching control term, κ is strictly positive constant and $\text{sign}(s)$ is a signum function.

$$\text{sign}(s) = \begin{cases} 1, & \text{if } s > 0, \\ 0, & \text{if } s = 0, \\ -1, & \text{if } s < 0. \end{cases} \quad (20)$$

The convergence condition which makes the area attractive and invariant is defined by the Lyapunov equation [10] is:

$$S.S \leq 0 \quad (21)$$

A. Application of SMC to DFIG

This technique has been used to control the rotor currents (i_{rq}) and (i_{rd}) which are the images of the (P_s) and (Q_s) , respectively. In DFIG sliding mode control theory, the surfaces are chosen according to the errors as;

$$\left. \begin{aligned} e_1 &= P_{sref} - P_s \\ e_2 &= Q_{sref} - Q_s \end{aligned} \right\} \quad (22)$$

If the slope of sliding surface $n=1$ is taken, the surfaces become;

$$\begin{aligned} s(P) &= P_{sref} - P_s, \\ s(Q) &= Q_{sref} - Q_s. \end{aligned} \quad (23)$$

By deriving surfaces with the replacement of the powers P_s and Q_s refer to (12)-(13), and currents i_{rd} and i_{rq} refer to (14)-(15), the following is obtained.

$$s(P) = P_{sref} + V_s \frac{L_m}{L_s} \left(\frac{1}{(1 - \frac{L_m^2}{L_s L_r})} \left(\frac{R_r}{L_r} + \frac{L_m^2 R_s}{L_s^2 L_r} \right) - g \omega_s i_{rd} + \frac{1}{(1 - \frac{L_m^2}{L_s L_r}) L_r} V_{rq} \right) \quad (24)$$

$$s(Q) = Q_{sref} + V_s \frac{L_m}{L_s} \left(-\frac{R_r}{L_r (1 - \frac{L_m^2}{L_s L_r})} i_{rd} + g \omega_s i_{rq} + \frac{1}{(1 - \frac{L_m^2}{L_s L_r}) L_r} V_{rd} \right) - \frac{V_s^2}{L_s \omega_s} \quad (25)$$

Here, i_{rq} and i_{rd} are control vectors push the system trajectories to the sliding surface. During the sliding mode and in steady state, there are,

$$s(P) = 0, \dot{s}(P) = 0, i_{rq}^n = 0, s(Q) = 0, \dot{s}(Q) = 0, i_{rd}^n = 0. \quad (26)$$

Consequently, the equivalent controls become:

$$i_{rq}^{eq} = \left(\frac{L_s \sigma L_r}{L_m V_s R_r} P_{sref} - \frac{g \omega_s \sigma L_r}{R_r} i_{rd} + \frac{V_{rq}}{R_r} - \frac{L_m g V_s}{R_r L_s} \right) \quad (27)$$

$$i_{rd}^{eq} = \left(Q_{sref} \frac{\sigma L_r L_s}{V_s R_r L_m} + \frac{g \omega_s \sigma L_r i_{qr} + V_{rd}}{R_r} - \frac{\sigma L_r V_s}{R_r L_m \omega_s} \right) \quad (28)$$

where σ is the leakage coefficient $[\sigma = 1 - L_m^2 / L_s L_r]$.

B. Application of Adaptation to DFIG

The main feature of SMC is the robustness against the parameter variations and external disturbances. In this section,

the coefficient (κ) of the switching signal is adaptively adjusted.

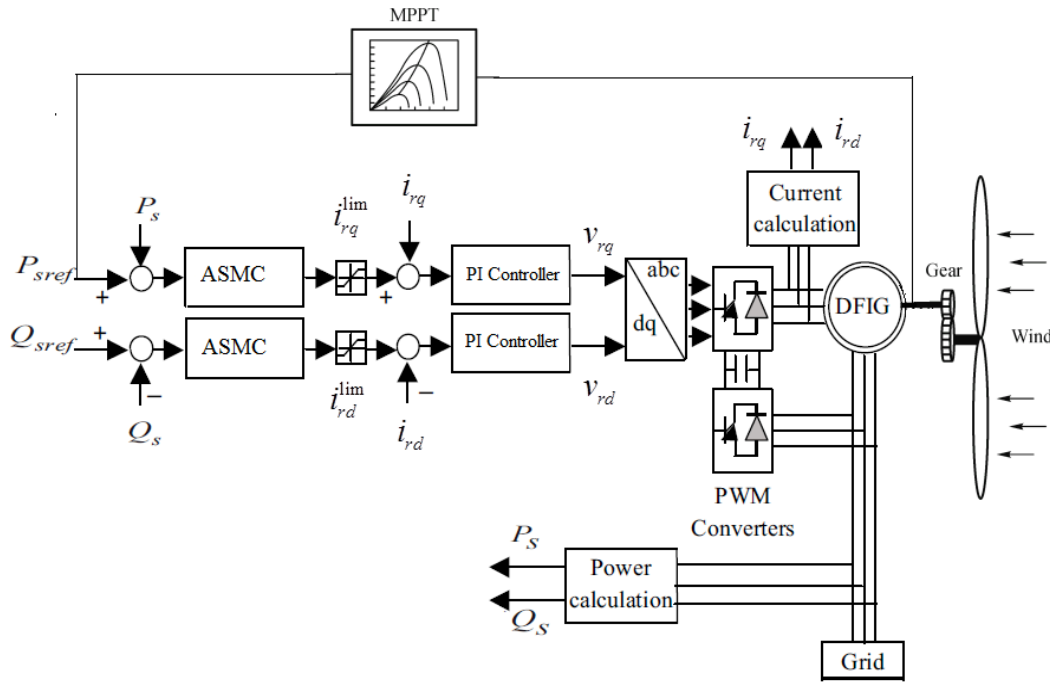

Fig.2. The closed loop schematic diagram of DFIG controlled by ASMC

Hence, adaptive switching control term u_{as}^n can be arranged as in [15],

$$u_{as}(t) = \eta \text{sgn}(s) \quad (29)$$

η shows the adjustable positive gain and when the adaptation coefficient ($\rho > 0$), it is modified as;

$$\eta = \frac{1}{\rho} |s| \quad (30)$$

The adaptation factor of (η) is adjusted by adaptation coefficient (ρ) which is strictly positive constant. Optimum (ρ) value ensures to avoid high frequency signals from the control input during the reaching reference point.

To reduce any possible overshoot of currents i_{rq} and i_{rd} , adding current limiters is often used.

$$\begin{aligned} i_{rq}^{\text{lim}} &= i_{rq}^{\text{max}} \text{sat}(i_{rq}) \\ i_{rd}^{\text{lim}} &= i_{rd}^{\text{max}} \text{sat}(i_{rd}) \end{aligned} \quad (31)$$

V. SIMULATION RESULTS

The closed loop control scheme for DFIG based Wind Turbine using ASMC-PI controllers is presented in Fig. 2. ASMC blocks represent the proposed control technique which determines reference currents. PI Controller blocks compare rotor currents with reference currents and compute rotor voltages. Coordinate transform block (dq\abc) converts synchronously rotating frame to stationary reference frame. PWM Converter block feeds the rotor through a convertor according to computed rotor voltages.

The block DFIG shows the doubly fed induction generator used in this work whose based data of the simulated: 1.5kW; 380V; 60 Hz. According to these based data: $R_s=0,0030608 \Omega$; $R_r=0,003068 \Omega$; $L_m=1,85068 \text{ H}$; $L_s=0,05783 \text{ H}$; $L_r=0,05783 \text{ H}$; $N_p=3$;

Case I: Step Change in Wind Speed

DFIG initially operates with rotor speed at $w_r = 0.858 pu$. From 2nd second, wind speed is linearly increased from 8,5m/s to 12m/s in 4 seconds. As a result, the DFIG active power (P_s) is controlled according to MPPT method and reactive power (Q_s) are controlled at their reference value 0.09pu. Wind speed, DFIG rotor speed w_r , output active power (P_s), output reactive power (Q_s), are shown in Fig. 3 a, b, c, d, e, respectively.

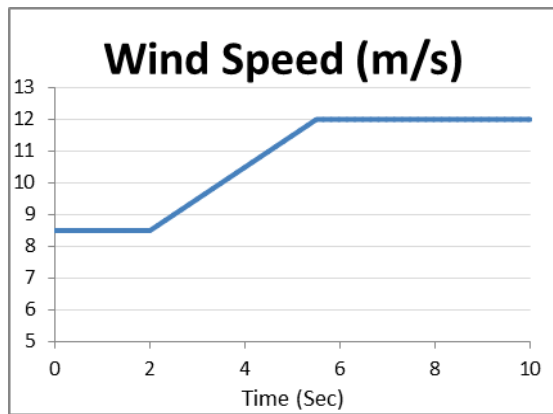

a) Reference wind speed for case I (m/s)

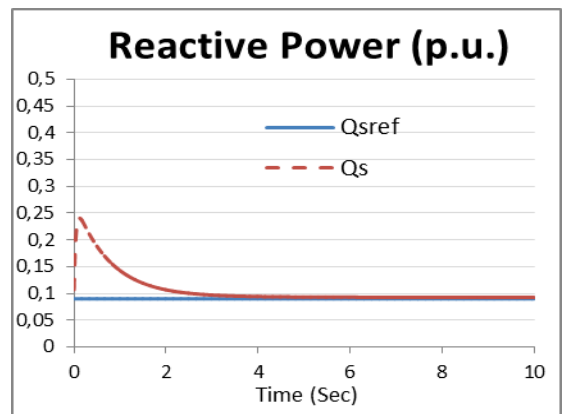

e) Generator reactive power according to reference wind speed

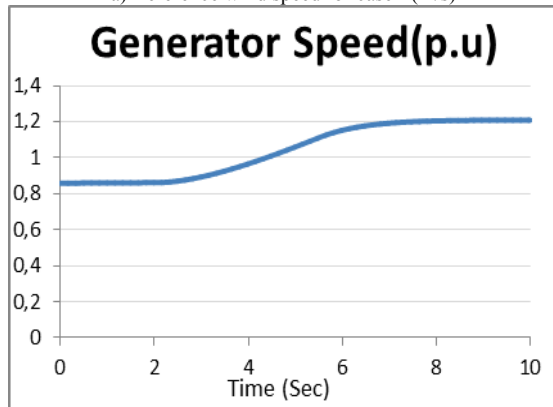

b) Generator speed according to reference wind speed

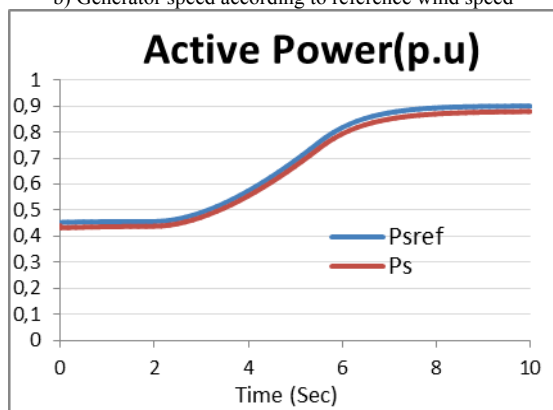

c) Generator active power according to reference wind speed

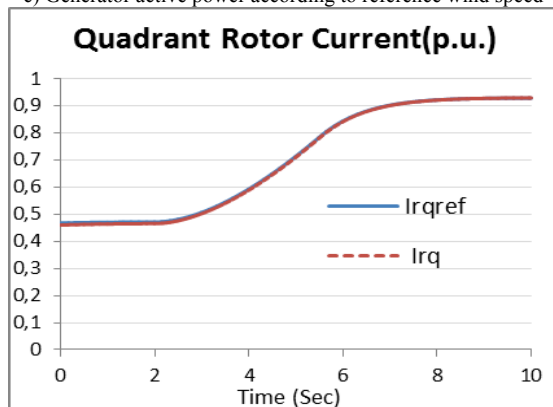

d) Generator rotor current according to reference wind speed

Fig.3. Effect of the ASMC Controller when Step Change in Wind Speed

Case II: Wind Speed with fluctuations

During the fluctuations in wind speed, ASMC-PI controller based maximum active (P_s) tracking system is performed. Reference reactive power (Q_{sref}) is set to 0,09pu. Wind speed, DFIG rotor speed, output active power (P_s) and output reactive power (Q_s) ratio are shown in Fig.4.

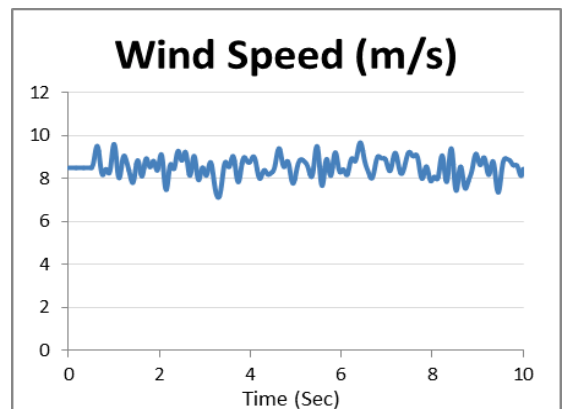

a) Reference wind speed for case II (m/s)

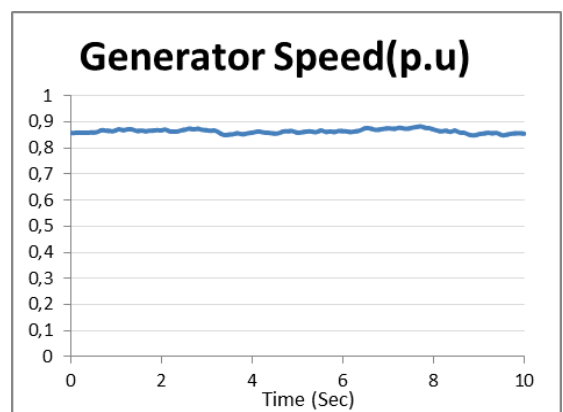

b) Generator speed according to reference wind speed

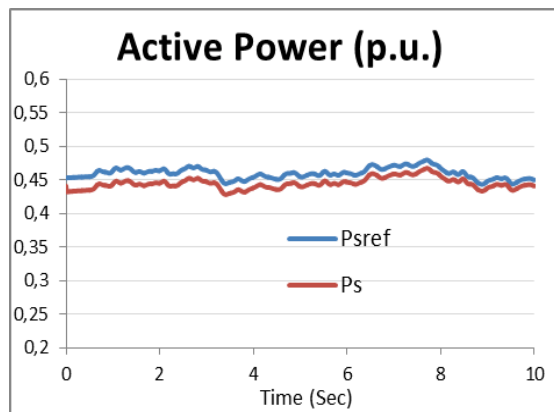

c) Generator active power according to reference wind speed

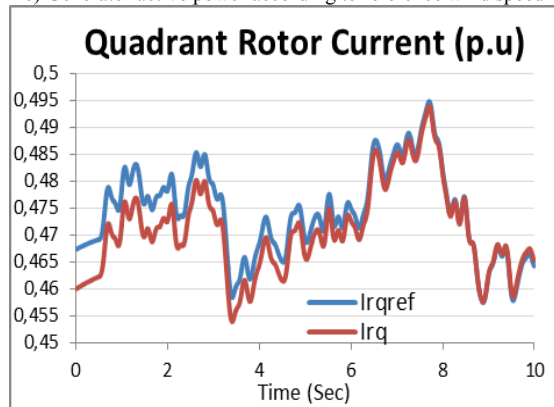

d) Generator rotor current according to reference wind speed

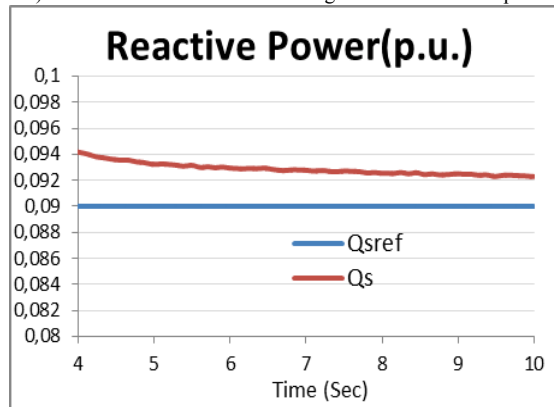

e) Generator reactive power according to reference wind speed

Fig.4. Effects of the ASMC-PI Controller when Wind with fluctuations

VI. CONCLUSION

In this study, adaptive sliding mode control of the double fed induction generator using the field-oriented control method is proposed. After modeling system and designing controllers, two different wind conditions have been chosen to prove effectiveness of the proposed control system. Results show that the proposed control method is well performed in adjusting reference rotor currents, and tracking desired active and reactive power under smooth winds and turbulences. LabVIEW software is used for simulation studies.

REFERENCES

- [1] Johansson, Thomas B. Renewable energy: sources for fuels and electricity. Island press, 1993.
- [2] Larsson, Åke. The power qualities of wind turbines. Chalmers University of Technology, 2000.
- [3] Ko, Hee-Sang, et al. "A PI control of DFIG-based wind farm for voltage regulation at remote location." Power Engineering Society General Meeting, 2007. IEEE. IEEE, 2007.
- [4] Brekken, Ted, and Ned Mohan. "A novel doubly-fed induction wind generator control scheme for reactive power control and torque pulsation compensation under unbalanced grid voltage conditions." Power Electronics Specialist Conference, 2003. PESC'03. 2003 IEEE 34th Annual. Vol. 2. IEEE, 2003.
- [5] Brekken, Ted, Ned Mohan, and Tore Undeland. "Control of a doubly-fed induction wind generator under unbalanced grid voltage conditions." Power Electronics and Applications, 2005 European Conference on. IEEE, 2005.
- [6] Lopez, Jesus, et al. "Dynamic behavior of the doubly fed induction generator during three-phase voltage dips." IEEE TRANSACTIONS ON ENERGY CONVERSION EC 22.3 (2007): 709.
- [7] Demirtas, Metin, Yusuf Altun, and Ayhan Istanbulu. "Virtual laboratory for sliding mode and PID control of rotary inverted pendulum." Computer Applications in Engineering Education 21.3 (2013): 400-409.
- [8] Senol, Ibrahim, et al. "Position control of induction motor a new-bounded fuzzy sliding mode controller." COMPEL-The international journal for computation and mathematics in electrical and electronic engineering 24.1 (2005): 145-157.
- [9] Leu, Viet Quoc, Han Ho Choi, and Jin-Woo Jung. "Fuzzy sliding mode speed controller for PM synchronous motors with a load torque observer." Power Electronics, IEEE Transactions on 27.3 (2012): 1530-1539.
- [10] Ha, Quang Phuc, et al. "Fuzzy sliding-mode controllers with applications." Industrial Electronics, IEEE Transactions on 48.1 (2001): 38-46.
- [11] Alam M.T., Charam P., Alam Q., Purwar S., "Sliding Mode Control of Coupled Tanks System: Theory and an Application" International Journal of Emerging Technology and Advanced Engineering, Vol. 3, No. 8, 2013, pp. 650-656.
- [12] Burton, Tony, et al. Wind energy handbook. John Wiley & Sons, 2001.
- [13] J. Y. Hung, W. Gao, and J. C. Hung, "Variable structure control: A survey", IEEE Trans. Ind. Electron., vol. 40, no. 1, pp. 2-22, Feb. 1993.
- [14] Bekakra, Youcef, and Djilani Ben Attous. "DFIG sliding mode control fed by back-to-back PWM converter with DC-link voltage control for variable speed wind turbine." Frontiers in Energy 8.3 (2014): 345-354.
- [15] Huang, Ying-Jeh, Tzu-Chun Kuo, and Shin-Hung Chang. "Adaptive sliding-mode control for nonlinear systems with uncertain parameters." Systems, Man, and Cybernetics, Part B: Cybernetics, IEEE Transactions on 38.2 (2008): 534-539.
- [16] Xiao, D., and M. F. Rahman. "Direct Torque Control of an Interior Permanent Magnet Synchronous Machine fed by a Direct AC-AC Converter." Power Electronics and Motion Control Conference, 2006. IPEMC 2006. CES/IEEE 5th International. Vol. 3. IEEE, 2006.